

1227MHz Adaptive Notch Filter

Product Description

The A236001-1 is a very highly integrated multi-function module that provides adaptive notch filtering for use in advanced interference mitigation (anti-jam) systems. This device accepts two input signals with independent phase/amplitude characteristics centered at approximately 1227MHz and processes these two signals using a variety of amplifier stages, variable phase shifters, amplitude modulators, and quadrature hybrids. Externally applied control signals are used to either cancel the signal at the selected output port or to enable the combined signal to pass through un-attenuated. All circuit functions are realized using lumped element components integrated in a hermetic $1.4 \times 1.5 \times 0.12$ inch surface mount package. This Adaptive Notch Filter is intended for high reliability military GPS applications.

Product Features

- Complex, Highly Integrated, GPS Anti-Jam Function
- Gain in Maximum Gain State > 30dB
- Integral Gain vs. Temperature Compensation
- Adaptive Notch Depth > 25dBc for ± 15 MHz Bandwidth and > 60dBc at Center Frequency
- Noise Figure < 3dB (Max Gain State)
- Flat Group Delay
- Integral Differential Drivers for High Speed Analog Control Signals
- Miniature $1.4 \times 1.5 \times 0.12$ Inch Hermetic Surface Mount Package
- Operates from -45°C to $+85^{\circ}\text{C}$



Functional Block Diagram

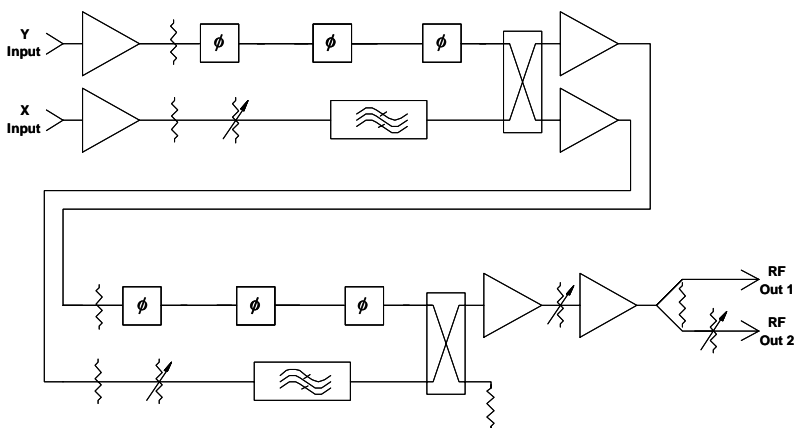

Electrical Specifications

Parameter	Units	Typical
Frequency	MHz	1210 to 1245
Gain (Max Gain State)	dB	32
Gain Flatness	dB	< 1
I/O VSWR		< 1.5:1
Notch Filter Depth (Full Band)	dBc	> 30
Output P1dB	dBm	> 4.0
Noise Figure	dB	< 3.0
DC Bias	V	5 @ 150mA
Operating Temperature Range	$^{\circ}\text{C}$	-45 to +85

1227MHz Adaptive Notch Filter

Typical Electrical Performance

Maximum Gain Response

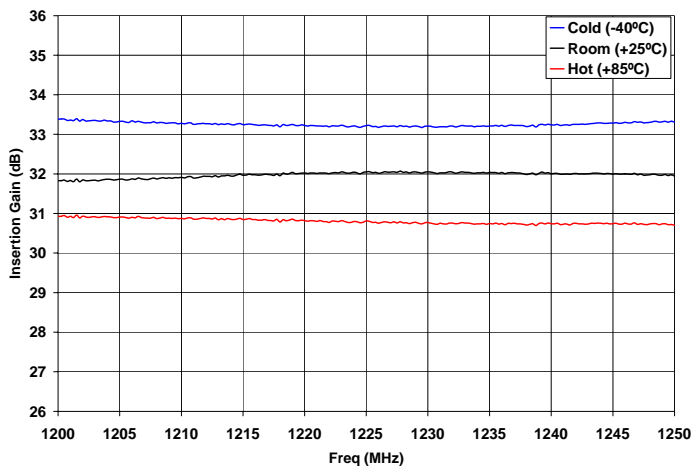

Notch Filter Response

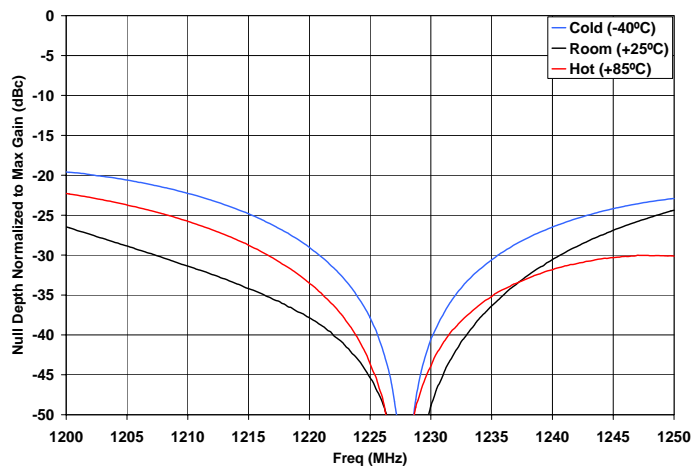

Group Delay @ Maximum Gain

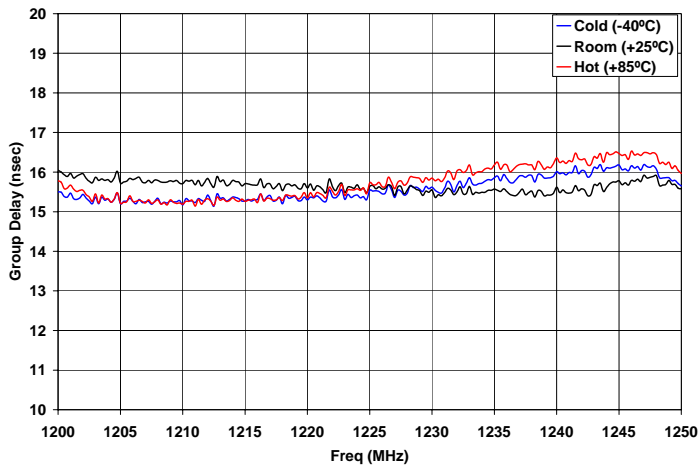

Input to Input Isolation @ 25°C

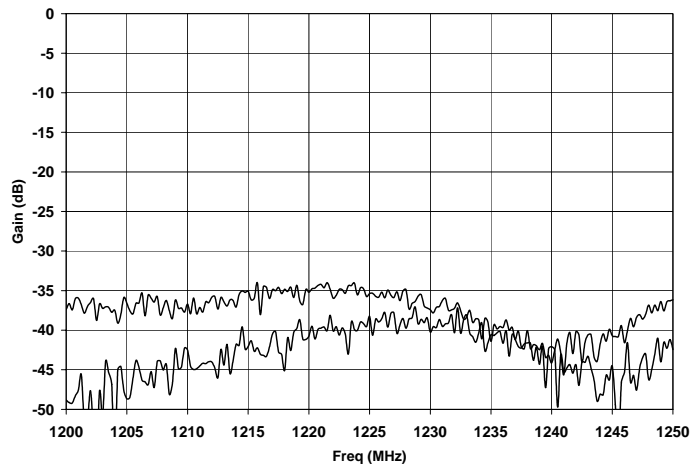

Outline

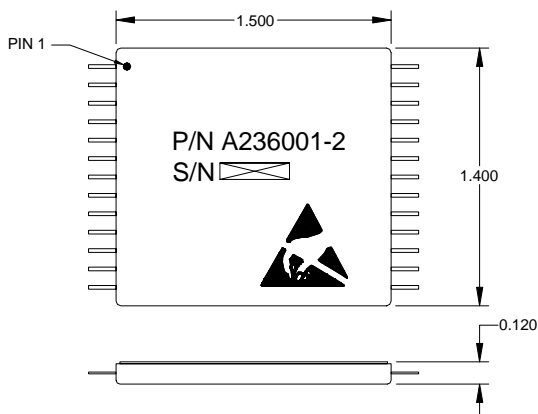

Rev - 12/7/06

Microwave Concepts, Inc.

A Division of Micronetics, Inc.

12 Gardner Road, Fairfield, NJ 07004 Telephone: 973-244-1040 Fax: 973-244-1188

Web: www.micro-con.com E-mail: sales@micro-con.com